

Tool Storage Fixture

To securely hold tooling while not in use, Applied Robotics offers a tool storage fixture plate designed for the XC1, BXC5, CXC10, BXC20 and CXC30 models.

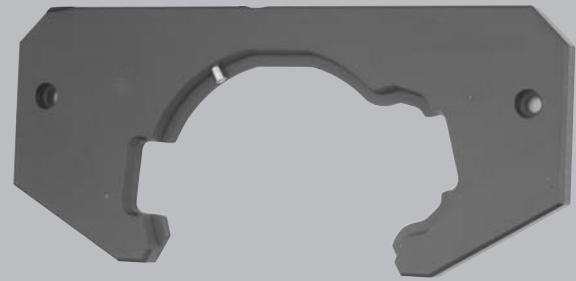

BX20 shown

Features and Benefits

- Tool presence sensor verifies an empty fixture before replacing tool
- Tool presence sensor prevents uncoupling of your tool before it is nested in the fixture
- Minimal footprint design maximizing workspace ability
- Pre-drilled holes for easy mounting

Not exactly what your application requires? Applied Robotics can design a solution that meets your particular application needs.

SPECIFICATIONS

Model	Description
XC1	XChange Tool Support Fixture Plate
BXC5	XChange Tool Support Fixture Plate
BXC20	XChange Tool Support Fixture Plate
CXC10	XChange Tool Support Fixture Plate
CXC30	XChange Tool Support Fixture Plate

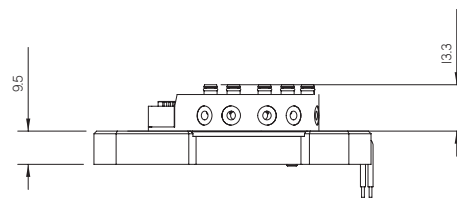
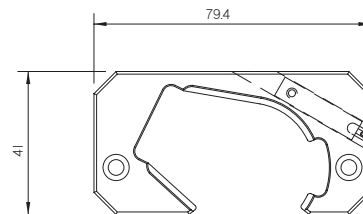

All dimensions in millimeters

XC1

continued

Engineering Data

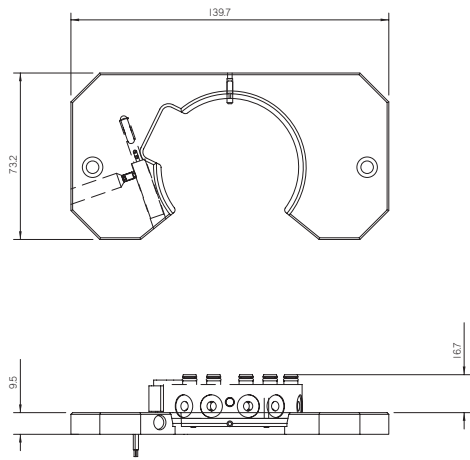

BXC5

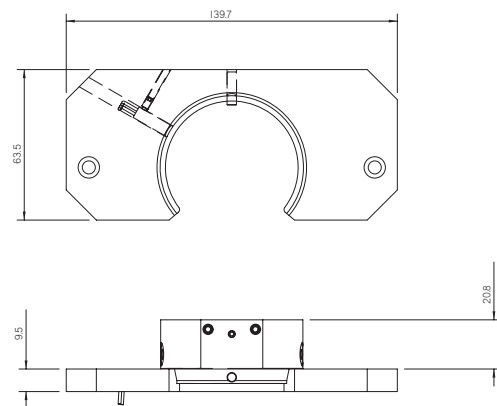

CXC10

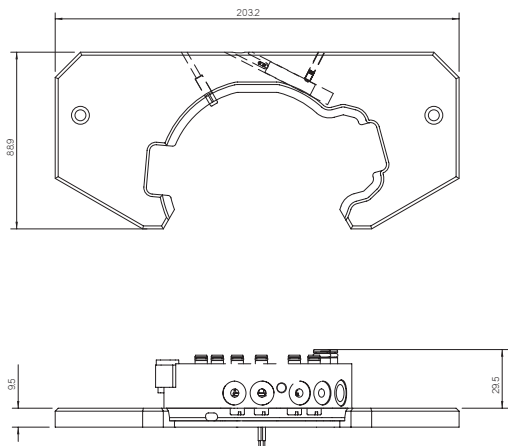

BXC20

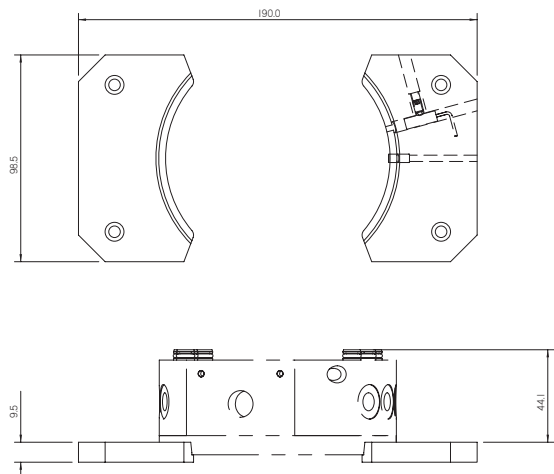

CXC30

All dimensions in millimeters